



Potato Peelers

Models:

-
- | | |
|-----------|---------------------------------|
| #177PPC22 | 22 lb. Countertop • 120V • 1 HP |
| #177PPF40 | 40 lb. Floor • 120V • 1 1/2 HP |
-

Warning:

Read and understand all INSTRUCTIONS before operating. Failure to follow the safety rules and other basic safety precautions may result in serious personal injury.

Table of Contents

Troubleshooting.....	3
Operation	5
Access Point	6
Part Testing: Overload Breaker.....	6
Part Testing: Emergency Stop Switch	7
Part Testing: Pulse Momentary Switch	7
Part Testing: Indicator Lights.....	8
Part Testing: Timer Switch	8
Part Testing: Lid Reed Switch	9
Part Testing: Side Door Reed Switch.....	9
Part Testing: Centrifugal Switch	10
Part Testing: Motor Contactor.....	10
Part Testing: Drive Motor	11
Part Testing: Motor Capacitors	11
Part Replacement: Overload Breaker	12
Part Replacement: Emergency Stop Switch.....	12
Part Replacement: Pulse Momentary Switch	12
Part Replacement: Indicator Lights	13
Part Replacement: Lid Reed Switch.....	13
Part Replacement: Side Door Reed Switch.....	14
Part Replacement: Centrifugal Switch.....	14
Part Replacement: Drive Motor.....	15
Part Replacement: Driveshaft Assembly and Belt.....	16
Part Replacement: Motor Capacitors.....	17
Part Replacement: Motor Contactor	17
Wiring Diagram.....	18
Parts Diagram.....	19

Troubleshooting

Motor does not turn (unit plugged in).

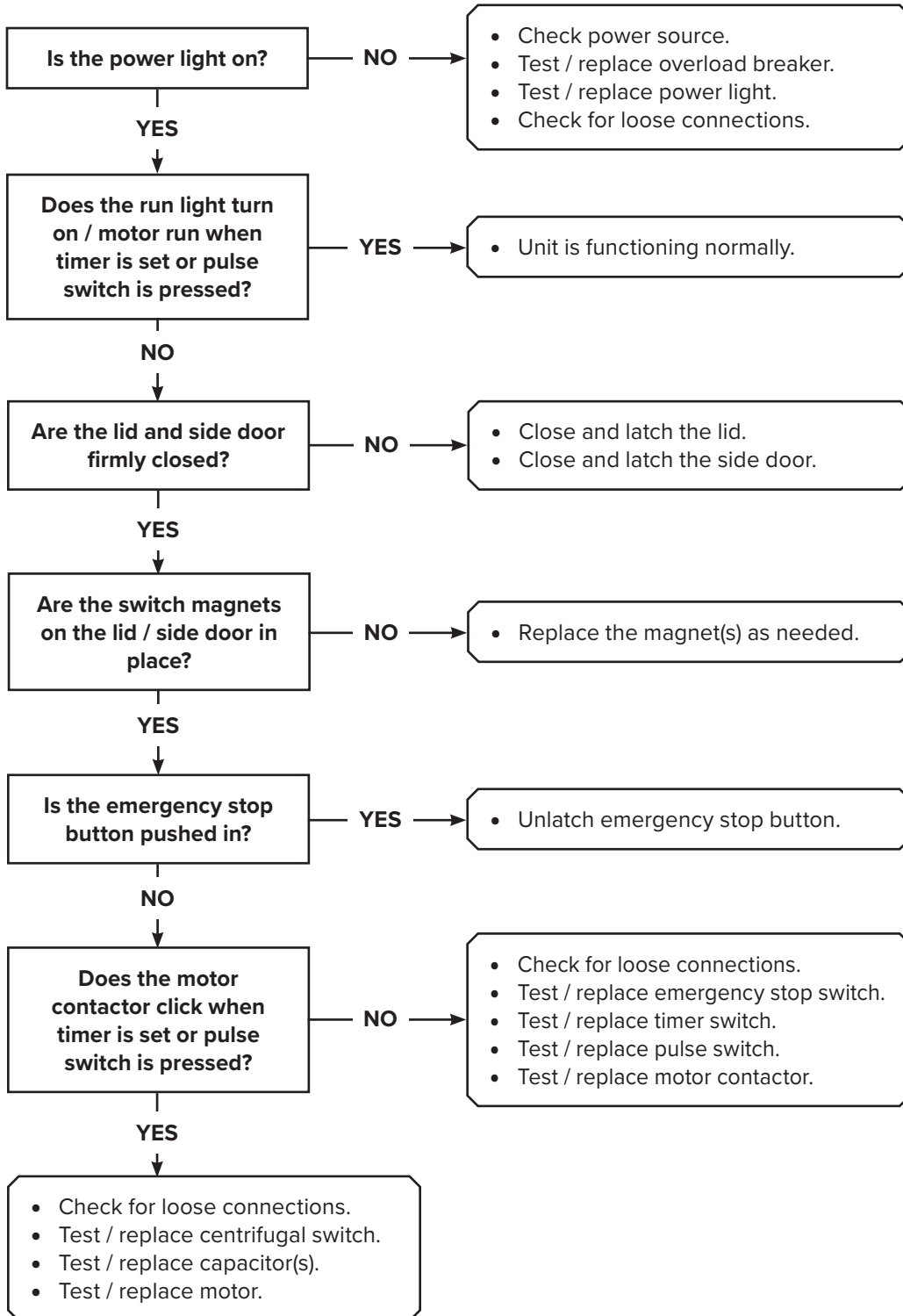

Troubleshooting

Power and run lights on, rotor plate doesn't turn.

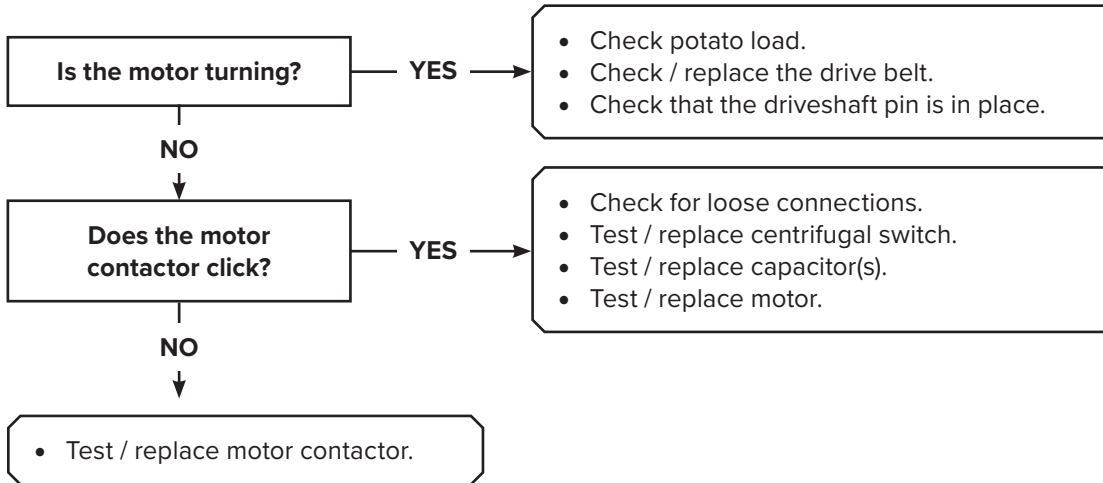

Unit has excessive vibration.

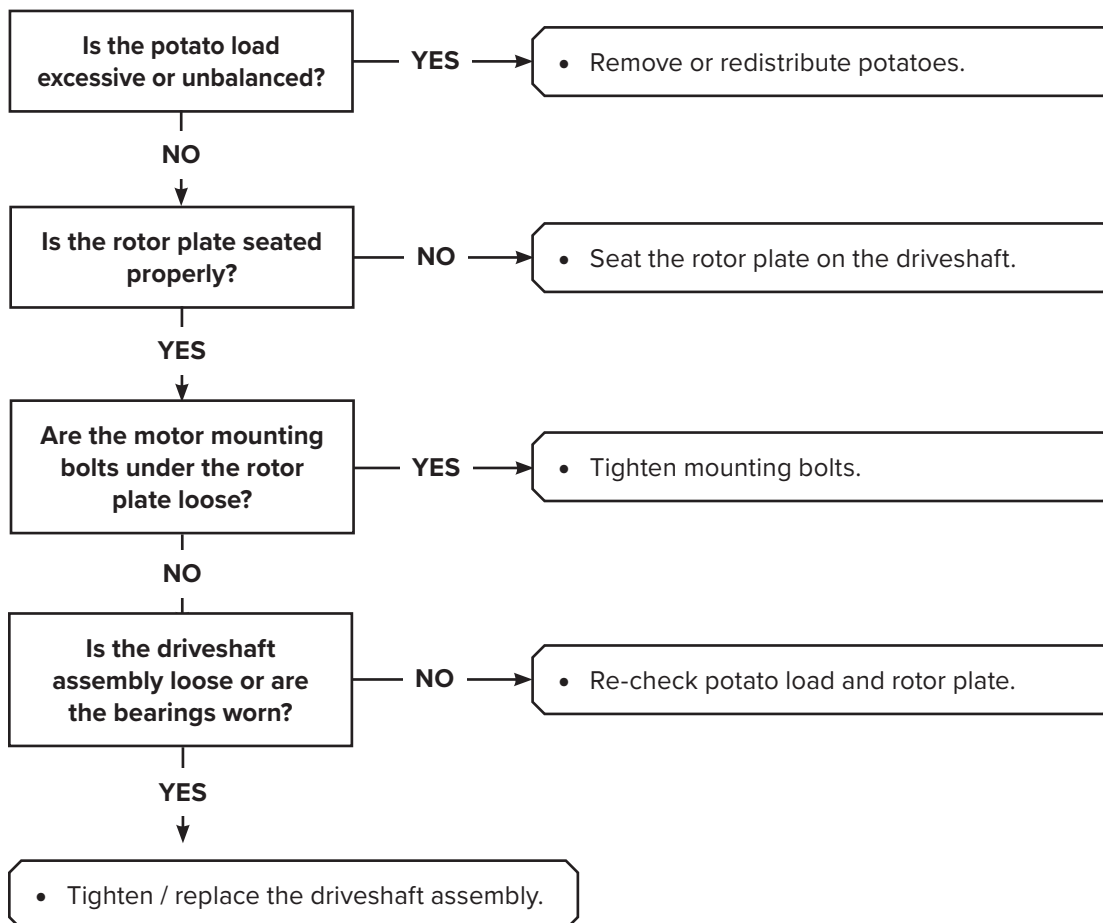

Operation

Peeling Potatoes

1. Open the hinged lid by pulling the handle until it clicks open.
2. Insert the peeling disk and load the tank with the product to be processed.
 - **NOTE:** Do not exceed the maximum weight of the unit.
3. Lock the lid and make sure the outlet door / delivery chute is closed and locked.
 - **NOTE:** There are micro switches in the lid and outlet door that will not allow the machine to run with the timer if they are open. The side door can be opened and will allow the machine to be pulsed using the manual switch so potatoes can be ejected. Do not reach into the unit when performing this operation.
4. Plug the unit into the wall outlet. The power indicator light will illuminate.
5. Start the machine by turning the timer knob to the desired cycle length. The running indicator light will illuminate. Ensure rinsing water is flowing in from the water inlet.
6. When the cycle has completed, the unit will automatically stop. The running indicator light will go out.
7. Check the product through the top lid to ensure it is fully peeled. If it's not, repeat steps 5 and 6 until desired result is achieved.
8. Place a container below the delivery chute before emptying product.
9. Hold the outlet door open and press the pulse button to empty the tank of the product.
10. Repeat as necessary.
11. Clean the unit immediately after use. See the User's Manual for cleaning instructions.
 - **NOTE:** If the unit's power light does not turn on when the unit is plugged in, check the overload breaker is not tripped. Push the breaker button in to reset.
 - **NOTE:** If the power light is on but the unit does not run, ensure the emergency stop button is not pushed in. Rotate the button clockwise to reset.



Access Point Motor and Electrical Area

1. Unplug the peeler.
 2. Open the top lid and remove the rotor plate from the peeler (Fig. 1). The rotor plate lifts off of the drive shaft without tools.
 3. To avoid damaging the lid, it can be removed. Remove the lid by unfastening the lid hinge studs (Fig. 2) using a 4 mm Allen wrench and a 14 mm wrench (Fig. 3).
 4. Carefully lift the peeler and lay it upside down - 22 lb. peeler shown (Fig. 4).
 5. Remove the feet / mounting brackets or leg mounts and drain pans (depending on the size unit being serviced).
 6. Remove the bottom cover plate from the unit to expose the internal components (Fig. 5).
- **NOTE:** For all powered testing, ensure the rotor plate is removed. The lid and side door switches must be activated by having the lid and side door closed or a magnet in place at their switch heads if they are removed. The overload breaker must be reset and functional. The emergency stop switch must be sprung out. Either the timer must be set beyond zero OR the pulse switch must be held in to activate power. All of these devices are in series, so if any one of them are open, it will not allow power to the motor.

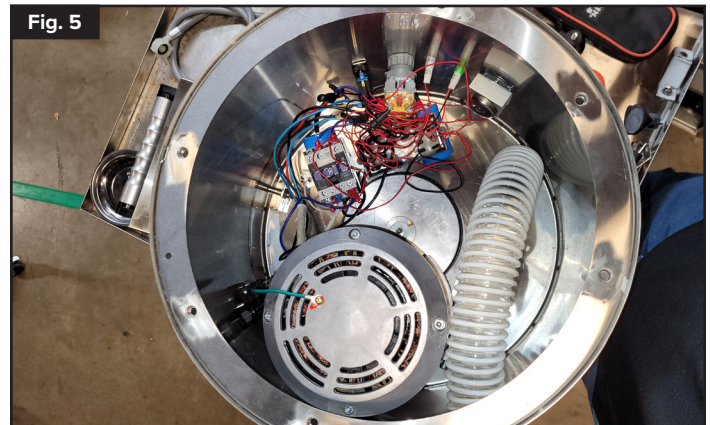
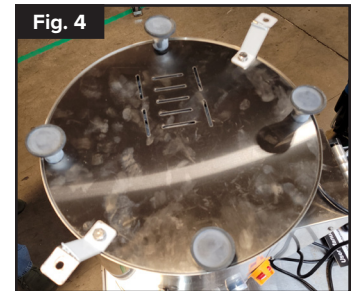
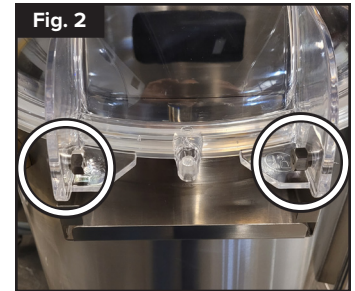

Part Testing

Overload Breaker

1. Unplug the peeler. Remove the rotor plate and access the motor and electrical area through the bottom of the peeler.
2. Locate the overload breaker on the peeler near the power cord (Fig. 6).
3. Remove the (2) wire leads from the breaker, noting their position (Fig. 7).
4. Ensure the breaker reset was pushed in and check for continuity between the (2) terminals. If there is no continuity, replace the breaker.

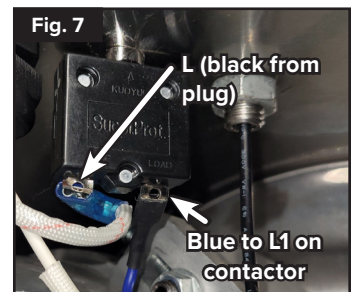

Part Testing

Emergency Stop Switch

1. Unplug the peeler. Remove the rotor plate and access the motor and electrical area through the bottom of the peeler.
2. Locate the emergency stop switch (Fig. 8). Remove the leads from the back of the switch, noting their location (Fig. 9).
3. With the switch knob sprung out, the switch is normally closed. Twist the red switch knob clockwise if it is not sprung out. Test for continuity between the outer two terminals on the switch. Push the switch back in and note that there should be no continuity between the two outer terminals.
4. If the switch does not function as above, or if it does not latch when pushed down and unlatch when twisted, replace the switch.



Pulse Momentary Switch

1. Unplug the peeler. Remove the rotor plate and access the motor and electrical area through the bottom of the peeler.
2. Locate the pulse switch (Fig. 10). Back the mounting nut off from the metal on the inside of the machine (Fig. 11). Twist the head of the switch on the outside of the machine counterclockwise 1/4 turn to release the switch body (Fig. 12). Pull the body of the switch out, noting their location.
3. There are two sets of switch wires to test. The side with a green tab is normally open (Fig. 13). The side with a red tab is normally closed (Fig. 11).
4. Check continuity on the green-tab side (Fig. 13). There should be no continuity with the switch at rest and continuity with the switch depressed.
5. Check continuity on the red-tab side (Fig. 11). There should be continuity with the switch at rest and no continuity with the switch depressed.
6. If the continuity does not match what is described above, replace the switch.

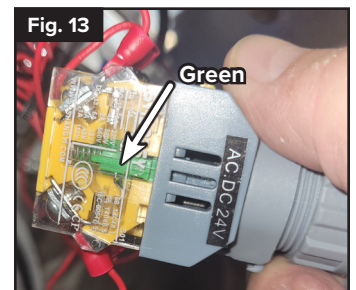
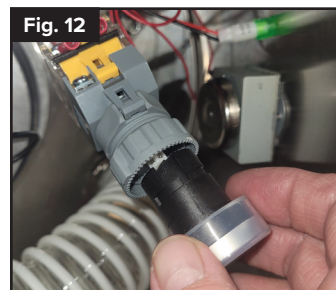
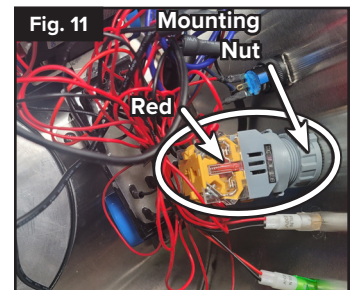

Part Testing

Indicator Lights

1. Unplug the peeler. Remove the rotor plate and access the motor and electrical area through the bottom of the peeler.
2. Locate the indicator lights on the peeler (Fig. 14).
3. Using needle probes on the multimeter, check for 140Ω (+/- 20%) resistance between the red and black wires on each light (Fig. 15). If there is high resistance or an open circuit, replace the light.
4. With the unit plugged in and the rotor plate still removed, close the lid or apply a magnet to the lid reed switch. Check for 120V at the pins marked 15 and 16 in the drawing (Fig. 16). This is for the power light. If there is voltage and the resistance in step 3 is correct but the indicator is not lit, replace the light.
5. With the unit plugged in and the rotor plate still removed, close the lid or apply a magnet to the lid reed switch. While pressing the pulse switch or turning the timer on, check for 120V at the pins marked 7 and 8 in the drawing (Fig. 16). This is for the running light. If there is voltage and the resistance in step 3 is correct but the indicator is not lit, replace the light.

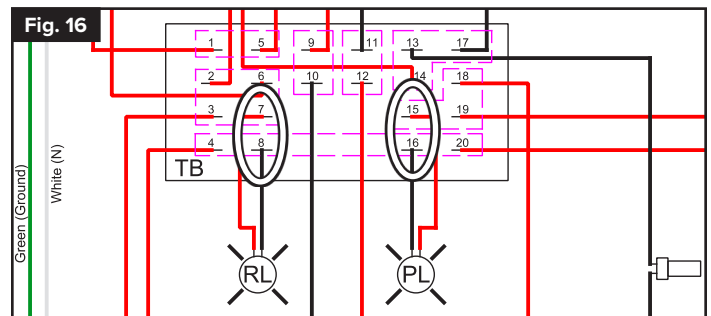
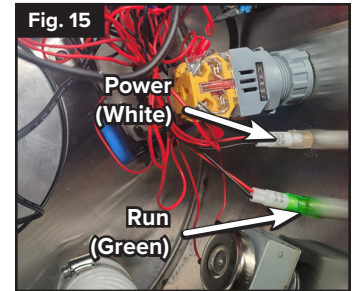

Timer Switch

1. Unplug the peeler. Remove the rotor plate and access the motor and electrical area through the bottom of the peeler.
2. Locate the timer switch (Fig. 17).
3. Access the mounting screws by removing the knob. Remove the (2) Phillips head mounting screws from the outside of the peeler (Fig. 18).
4. From the inside, remove the (2) wire leads on the switch, noting their position (Fig. 19).
5. With the timer turned past its '0' position, check for continuity between the (2) terminals on the switch. The timer should be ticking when turned past '0'. If there is no continuity, replace the timer switch.
6. If there is continuity, check the connections to the terminal block and voltage through the wire leads for other issues.

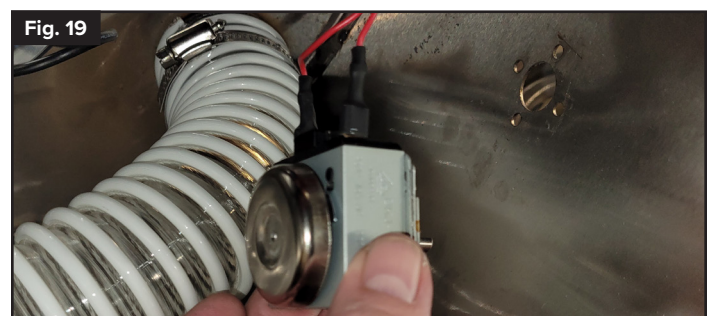

Part Testing

Lid Reed Switch

1. Unplug the peeler. Remove the rotor plate and access the motor and electrical area through the bottom of the peeler.
2. Locate the lid switch and magnet on the peeler lid (Fig. 20). If there is no magnet in the lid, a new one will need to be installed.
3. For reference, the lid switch cable runs through an external tube and comes in through the side wall of the unit near the overload breaker (Fig. 21).
4. Pull the (2) circled wire leads from the terminal board (Fig. 22). Using a magnet (or by closing the lid), check for continuity between the (2) leads. Remove the magnet (or open the lid) to check that there is no continuity between the leads. If the switch does not function in this manner, replace the switch.

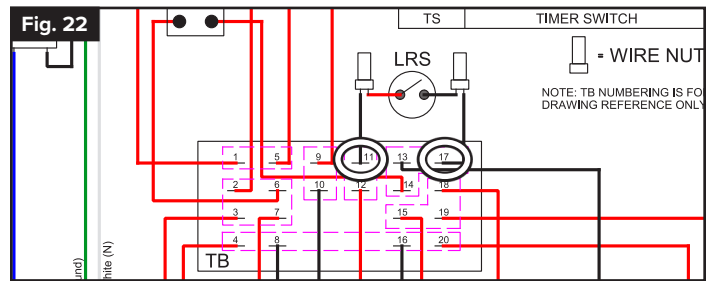
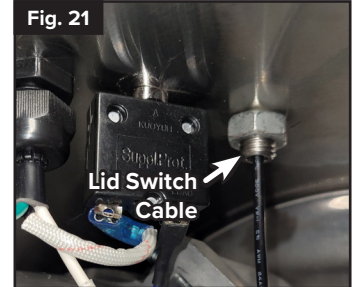
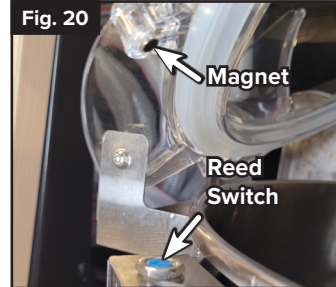

Side Door Reed Switch

1. Unplug the peeler. Remove the rotor plate and access the motor and electrical area through the bottom of the peeler.
2. Locate the side door magnet (Fig. 23). If there is no magnet in the door, a new one will need to be installed.
3. The switch body will be located on the inside of the peeler, directly behind the magnet when the side door is closed (Fig. 24).
4. Pull the (2) circled wire leads from the terminal board (Fig. 25). With the side door closed, check for continuity between the (2) leads. Open the side door to check that there is no continuity between the leads. If the switch does not function in this manner, replace the switch.

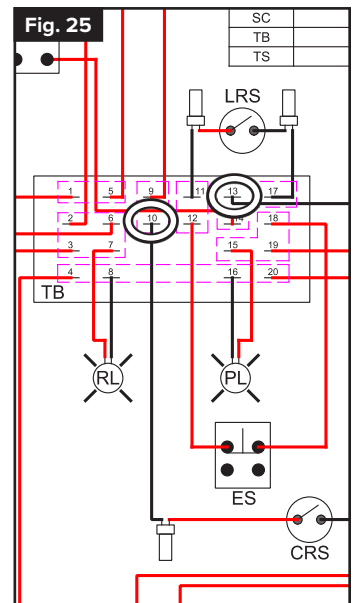
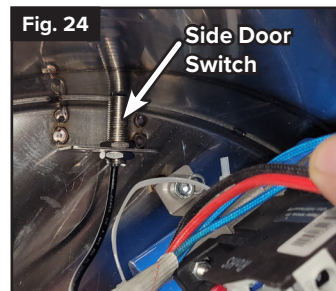
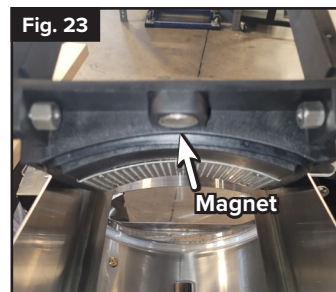

Part Testing Centrifugal Switch

1. Unplug the peeler. Remove the rotor plate and access the motor and electrical area through the bottom of the peeler.
 2. To access the switch, get clearance by first dismantling the pulse switch from the side of the peeler. Loosen the switch mounting nut, then turn the exterior button 1/4 turn counterclockwise to remove it (Fig. 26).
 3. Use a 5 mm Allen wrench to remove the (2) mounting screws holding the electrical component bracket from the peeler (Fig. 27).
 4. Make sure the electrical bracket and all wires are pulled away from the pulley and belt inside the unit. Clamp an amp meter to the red wire coming from the centrifugal switch (Fig. 28 and 29), and set the meter to "Max" mode to measure the maximum amps drawn when the motor first cycles.
 5. Double check that you have removed the rotor plate. Turn the timer on and check that the max amps at the red wire are approximately 8.5 amps (+/- 10%). With the motor still running, turn Max mode off on your meter and ensure there are now 0 amps drawn on the red wire.
- **NOTE:** The centrifugal switch controls the start capacitor. When power is first turned on, amps spike to the start capacitor and then shut off. This is to get the motor turning. Once running, the motor only uses the run capacitor, and the start capacitor has no current to it.

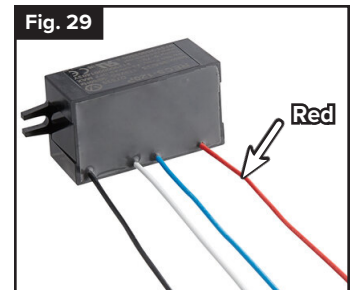
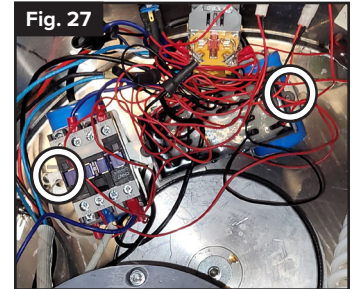
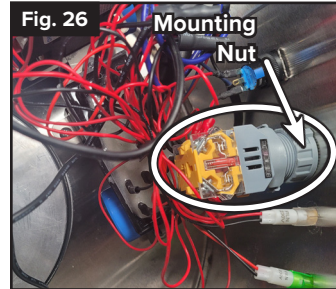

Motor Contactor

1. Unplug the peeler. Remove the rotor plate and access the motor and electrical area through the bottom of the peeler.
2. On the contactor, check for resistance of approximately 140Ω at the coil contacts.
3. Manually press down the contactor. Check for continuity from L1 to T1 and L3 to T3.
4. Plug the unit in. Check for line voltage (120Vac) between L1 and L3.
5. Turn the timer on and check for line voltage between T1 and T3. The contactor should actuate when the timer is on.
6. If any of the above do not match the contactor function, replace the contactor.

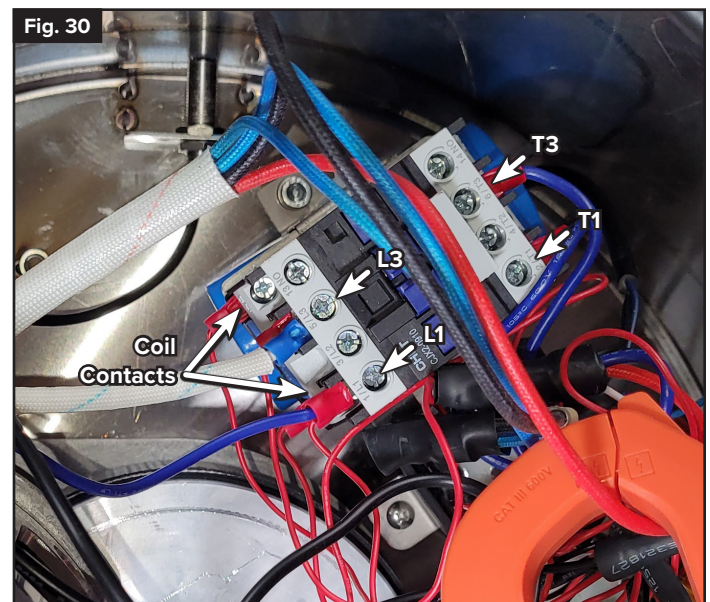

Part Testing

Drive Motor

1. Unplug the peeler. Remove the rotor plate and access the motor and electrical area through the bottom of the peeler.
2. If the motor can be run, plug in the peeler. Clamp an amp meter to the red high temperature wire coming from the motor (Fig. 31). Turn the timer on and check that the motor is drawing 5.1 amps (+/- 10%) and that it is spinning.
3. Unplug the peeler. Disconnect the high temperature insulated red and black wires from their wire nuts. Check for continuity between the red and black wires to ensure the motor windings are intact.
4. If the motor receives voltage but overdraws amps, has high/infinite winding resistance, or will not spin, replace the motor.
- **NOTE:** If the motor is spinning and passes the tests above, check that the belt is connected between the motor driveshaft and the drive pulley (Fig. 31).

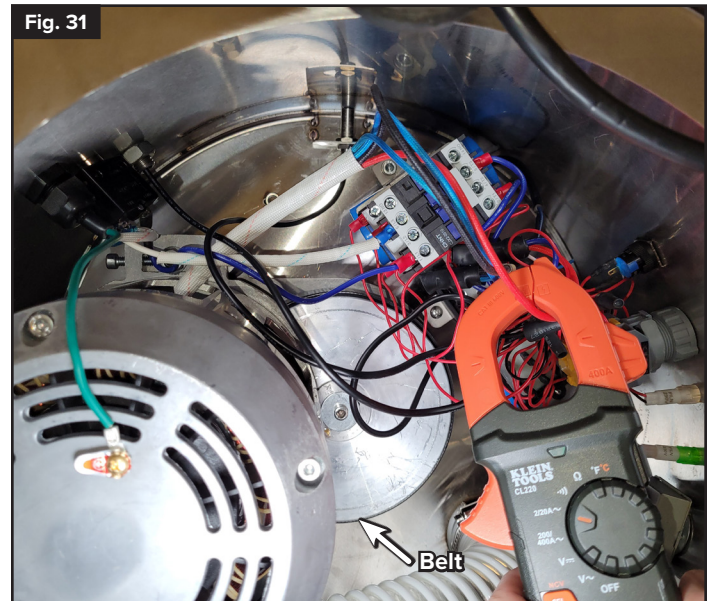

Motor Capacitors

1. Unplug the peeler. Remove the rotor plate and access the motor and electrical area through the bottom of the peeler.
2. To access the capacitors, get clearance by first dismantling the pulse switch from the side of the peeler. Loosen the switch mounting nut, then turn the exterior button 1/4 turn counterclockwise to remove it (Fig. 32).
3. Use a 5 mm Allen wrench to remove the (2) mounting screws holding the electrical component bracket from the peeler (Fig. 33).
4. Carefully remove the capacitor leads from their connections. Discharge the capacitor before testing using a 20KΩ, 2- watt carbon resistor. Use caution as the resistor will heat up quickly.
5. Use a multimeter with a capacitor testing function to test the capacitors to their labelled rating. The potato peeler capacitor ratings are as follows:
 - 177PPC22: 250μF Start, 60μF Run
 - 177PPF40: 250μF Start, 75μF Run
6. If a capacitor does not meet its labelled rating, replace the capacitor.

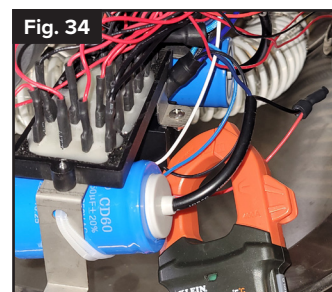
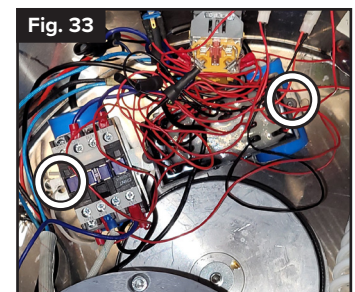
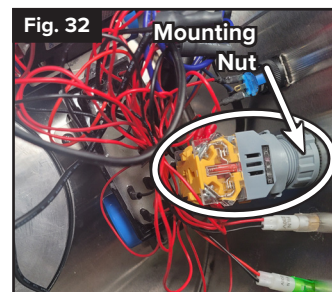

Part Replacement

UNPLUG UNIT BEFORE REPLACING PARTS.

Overload Breaker

1. Remove the rotor plate and access the motor and electrical area through the bottom of the peeler.
2. Locate the overload breaker on the peeler near the power cord (Fig. 35). Remove the knurled mounting nut from the external button.
3. Remove the (2) wire leads from the breaker on the inside of the unit, noting their position (Fig. 36).
4. Install the new breaker. Fasten it using the mounting nut. Reconnect the wire leads.

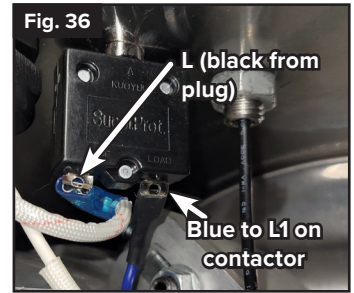

Emergency Stop Switch

1. Remove the rotor plate and access the motor and electrical area through the bottom of the peeler.
2. Locate the emergency stop switch (Fig. 37). Remove the leads from the back of the switch, noting their location (Fig. 38).
3. Unthread the mounting nut from the inside of the unit. Unthread the red button from the outside of the unit. Pull the switch out of the unit.
4. Install the new switch. Reconnect the wires. Ensure the switch button is popped out before use.



Pulse Momentary Switch

1. Remove the rotor plate and access the motor and electrical area through the bottom of the peeler.
2. Locate the pulse switch (Fig. 39). Back the mounting nut off from the metal on the inside of the machine (Fig. 40).
3. Twist the head of the switch on the outside of the machine counterclockwise 1/4 turn to release the switch body (Fig. 41). Pull the body of the switch out.
4. Remove the leads from the back of the switch, noting their location. The red-tab side (Fig. 40) is normally closed; the green-tab side is normally open (Fig. 42).
5. Install the new switch. Tighten the mounting nut on the inside and install the push button on the outside.
6. Reconnect the wire leads.

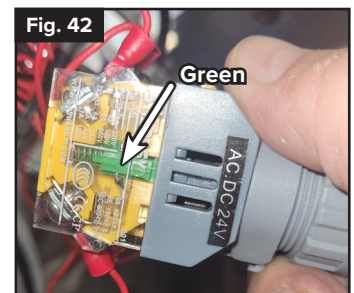
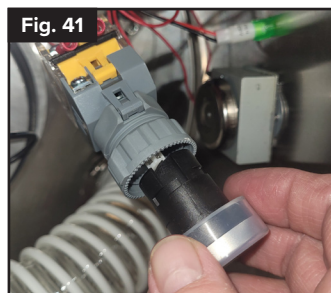
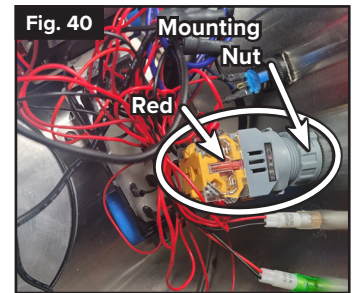

Part Replacement

UNPLUG UNIT BEFORE REPLACING PARTS.

Indicator Lights

1. Remove the rotor plate and access the motor and electrical area through the bottom of the peeler.
2. Locate the indicator lights on the peeler (Fig. 43 and 44).
3. Disconnect the light to be replaced from the terminal block. For the power light, the pins marked 15 and 16 in the drawing are the connections. For the running light, the pins marked 7 and 8 in the drawing are the connections (Fig. 45).
4. Press the tabs on either side of the light body on the inside of the peeler. Push the light out through the sidewall.
5. Push the new light into the mounting hole. Connect the new leads to the appropriate terminals on the terminal block.

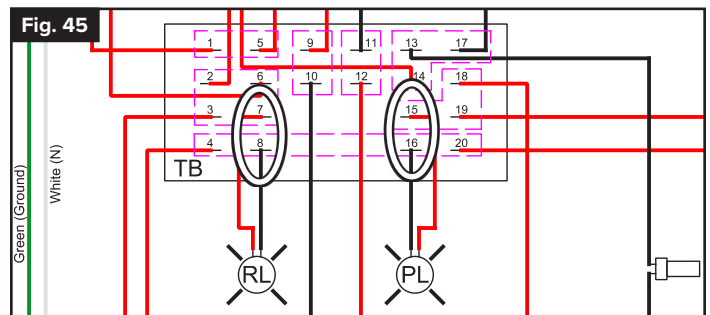
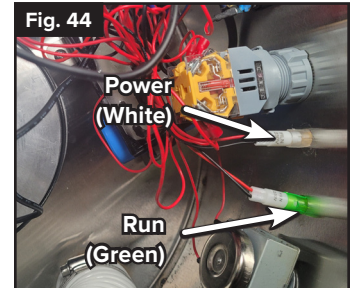

Lid Reed Switch

1. Unplug the peeler. Remove the rotor plate and access the motor and electrical area through the bottom of the peeler.
2. Locate the lid switch and magnet on the peeler lid (Fig. 46). If there is no magnet in the lid, a new one will need to be installed.
3. For reference, the lid switch cable runs through an external tube and comes in through the side wall of the peeler near the overload breaker (Fig. 47).
4. Disconnect the switch wires from their crimped connections (Fig. 48).
5. Loosen the tube nut for the bulkhead fitting where the switch cable goes through the peeler sidewall (Fig. 47).
6. Remove the nut at the top of the switch nearest the lid magnet (Fig. 46).
7. Loosen the Phillips screw holding the top of the tube (Fig. 49). Pull the tube down slightly and remove the lower switch from inside the bracket. Slide the switch and wires out of the peeler.
8. Feed the new switch and wires down through the exterior mounting tube and into the side of the peeler.
9. Reconnect the wires to their crimped connections and fasten the switch and tube in place.

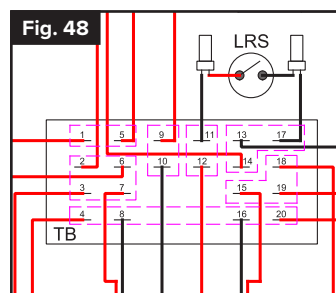
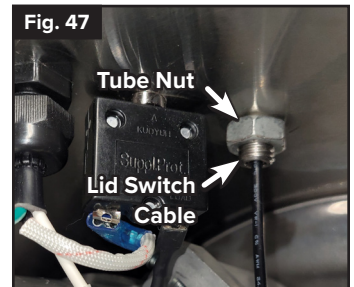
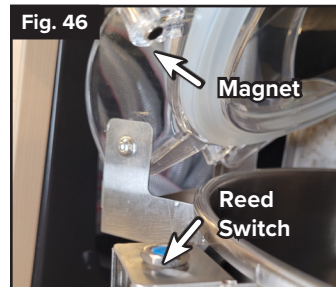

Part Replacement

UNPLUG UNIT BEFORE REPLACING PARTS.

Side Door Reed Switch

1. Remove the rotor plate and access the motor and electrical area through the bottom of the peeler.
2. Locate the side door magnet (Fig. 50). If there is no magnet in the door, a new one will need installed.
3. The switch body will be located on the inside of the peeler, directly behind the magnet when the side door is closed (Fig. 51).
4. Disconnect the switch wires from their crimped connections (Fig. 52).
5. Loosen the nuts holding the switch to its mounting bracket and remove the switch.
6. Install the new switch. Reconnect the wires to their crimped connections.

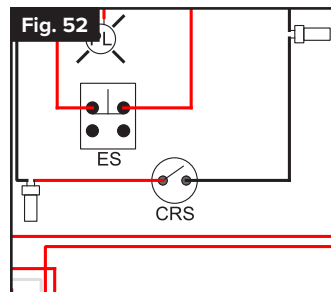
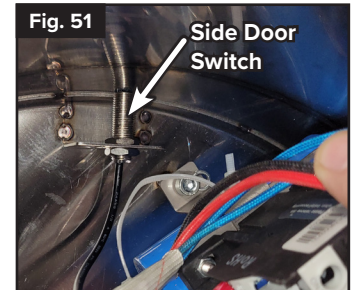
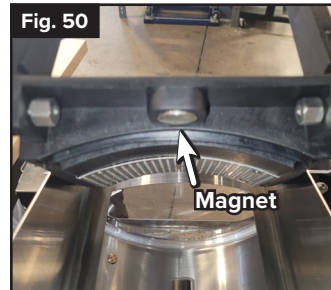

Centrifugal Switch

1. Remove the rotor plate and access the motor and electrical area through the bottom of the peeler.
2. To access the switch, get clearance by first dismounting the pulse switch from the side of the peeler. Loosen the switch mounting nut, then turn the exterior button 1/4 turn counterclockwise to remove it (Fig. 54).
3. Use a 5 mm Allen wrench to remove the (2) mounting screws holding the electrical component bracket from the peeler (Fig. 55).
4. Use a Phillips screwdriver and small adjustable wrench to remove the (2) mounting screws and nuts from the switch, one on each side (Fig. 56).
5. Disconnect the (4) switch leads from their crimped connections, noting their locations (Fig. 57).
6. Connect the new switch leads to their appropriate locations.
7. Mount the switch to the bottom of the electrical component bracket using the screws and nuts from step 4.
8. Secure the electrical component bracket to the peeler using the (2) mounting screws from step 3.
9. Install the pulse switch that had been removed for clearance in step 2.

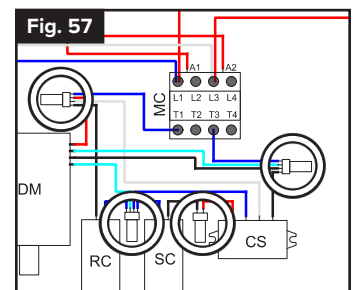
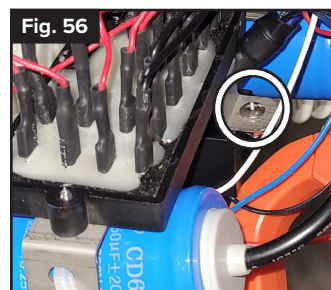
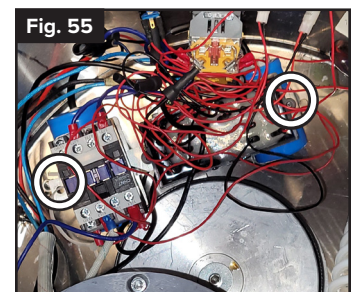
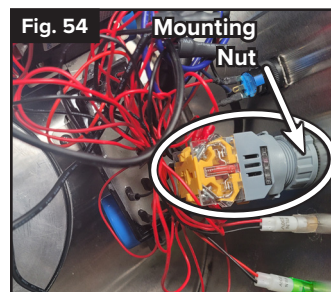

Part Replacement

UNPLUG UNIT BEFORE REPLACING PARTS.

Drive Motor

- **NOTE:** Butt connectors and shrink tube will be necessary to reconnect the motor wires if the motor is being replaced. If working alone, use a 6" piece of 2x4 to aid in holding the motor's weight during removal and install. The pulley, motor, and belt can be removed or installed as one assembly.
1. Remove the rotor plate and access the motor and electrical area through the bottom of the peeler.
 2. Cut the (4) motor wires leading to the motor at the end of the white woven loom (Fig. 58). Remove the Phillips screw holding the green ground wire to the motor case (Fig. 59).
 3. Push a 6" wood block under the motor assembly to assist in holding the weight when unbolted (Fig. 59).
 4. From the top side of the peeler, remove the (6) bolts using a 14 mm socket (Fig. 60). With the last bolt, support the motor as it is removed so the motor does not shift suddenly.
 5. Rotate and pull the motor assembly through the bottom of the unit (Fig. 61).
 6. Remove the nut from the mounting stud on each side of the motor (Fig. 62) using a 13 mm open crescent wrench.
 7. Using a 5 mm Allen wrench, loosen the belt tension screw on each side of the motor (Fig. 62) until the belt can be slipped off. Back the tension screw out to clear the slot to allow the driveshaft assembly bracket to be disassembled from the motor.
 8. Remove the (3) socket-head screws mounting the motor to the driveshaft assembly base using a 6 mm Allen wrench (Fig. 63).
 9. Mount the driveshaft assembly base onto the new motor using the screws from step 8. Place the driveshaft assembly onto its base.
 10. Install the belt. Install the (2) mounting nuts finger tight. Adjust the belt tension, then fully tighten the nuts on the studs.
 11. Rotate the motor assembly back into the peeler, using the block of wood as a guide. Fasten the assembly using the (6) bolts from step 4.
 12. Reconnect the wiring with butt connectors and shrink tube. Reconnect the ground wire.

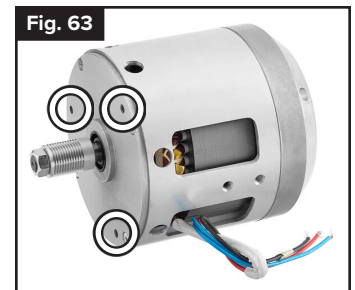
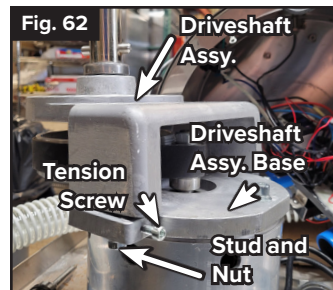
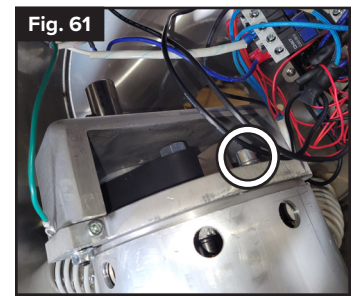
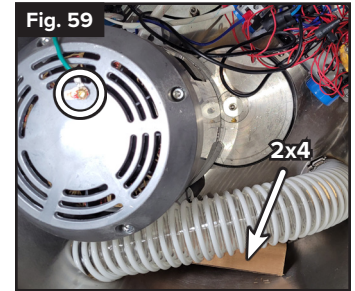
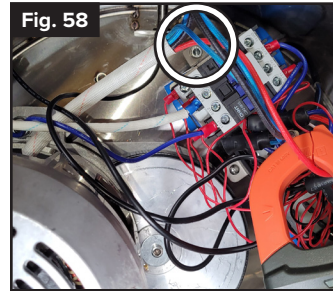

Part Replacement

UNPLUG UNIT BEFORE REPLACING PARTS.

Driveshaft Assembly and Belt

1. Remove the rotor plate and access the motor and electrical area through the bottom of the peeler.
2. Use a 5 mm Allen wrench to remove the (2) mounting screws holding the electrical component bracket from the peeler (Fig. 64). This will allow the electrical bracket and motor to be pulled without cutting the wiring.
3. Remove the Phillips screw holding the green ground wire to the motor case (Fig. 65).
4. Push a 6" wood block under the motor assembly to assist in holding the weight when unbolted (Fig. 65).
5. From the top side of the peeler, remove the (6) bolts using a 14 mm socket (Fig. 66). With the last bolt, support the motor as it is removed so the motor does not shift suddenly.
6. Rotate and pull the motor assembly and electrical component bracket through the bottom of the unit (Fig. 67).
7. Remove the nut from the mounting stud on each side of the motor (Fig. 68) using a 13 mm open crescent wrench.
8. Using a 5 mm Allen wrench, loosen the belt tension screw on each side of the motor (Fig. 68) until the belt can be slipped off. Back the tension screw out to clear the slot to allow the driveshaft assembly bracket to be disassembled from the motor.
9. Install the belt. Place the driveshaft assembly onto its base and install the (2) mounting nuts finger tight. Adjust the belt tension, then fully tighten the nuts on the studs.
10. Slide the motor assembly and electrical component bracket back into the peeler. Fasten the electrical component bracket to the peeler using the (2) mounting screws from step 2.
11. Rotate the motor assembly back into the peeler, using the block of wood as a guide. Fasten the assembly using the (6) bolts from step 5.

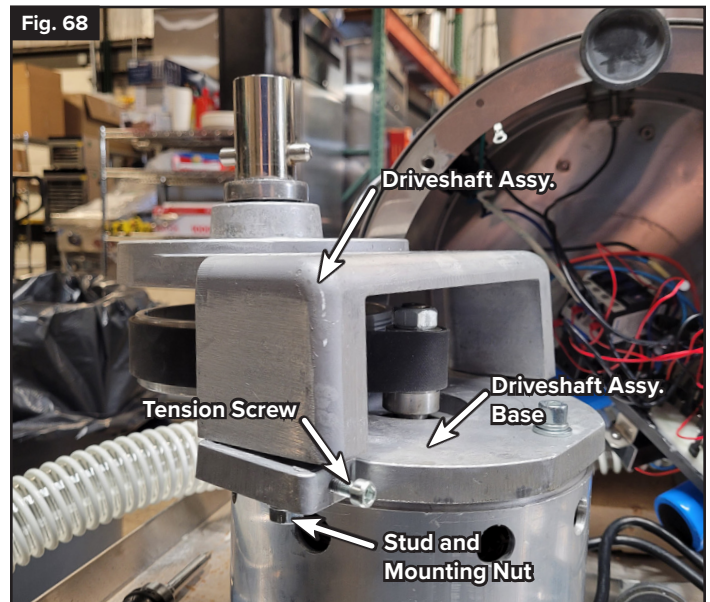
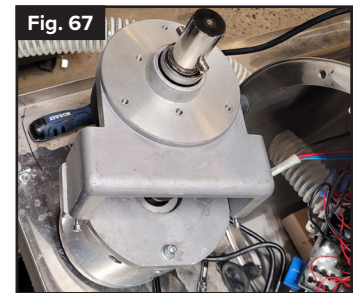
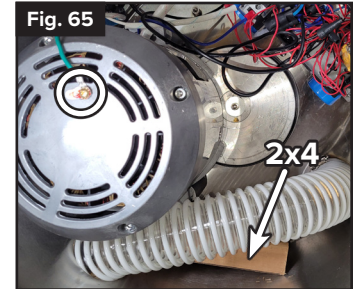
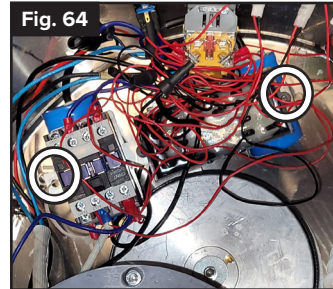

Part Replacement

UNPLUG UNIT BEFORE REPLACING PARTS.

Motor Capacitors

1. Remove the rotor plate and access the motor and electrical area through the bottom of the peeler.
2. Use a 5 mm Allen wrench to remove the (2) mounting screws holding the electrical component bracket from the peeler (Fig. 69).
3. Remove the wire ties mounting the capacitor to the bracket (Fig. 70).
4. Disconnect the capacitor leads from the crimped connections, noting the leads in each crimped connection (Fig. 71).
5. Connect the new capacitor leads and crimp on new connectors.
6. Mount the capacitor to the electrical component bracket using wire ties.
7. Fasten the electrical component bracket to the peeler using the screws from step 2.

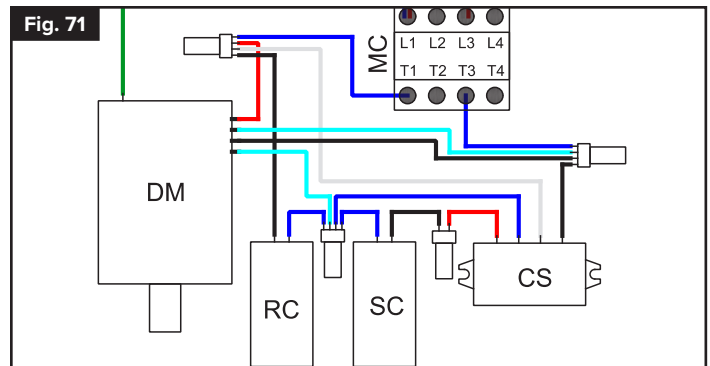
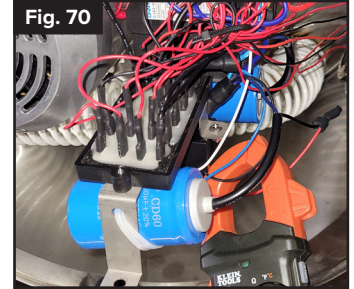
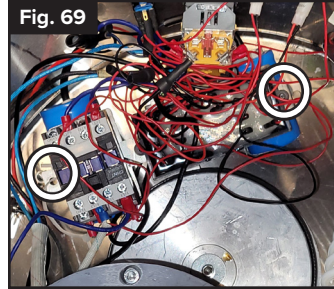

Motor Contactor

1. Remove the rotor plate and access the motor and electrical area through the bottom of the peeler.
2. Use a 5 mm Allen wrench to remove the (2) mounting screws holding the electrical component bracket from the peeler (Fig. 72).
3. Disconnect the contactor leads, noting their location.
4. Remove the mounting fasteners at each corner of the contactor using a Phillips screwdriver and a small adjustable wrench (Fig. 73).
5. Mount the new contactor to the electrical component bracket using the fasteners from step 4.
6. Reconnect the contactor leads.
7. Fasten the electrical component bracket to the peeler using the (2) mounting screws from step 2.

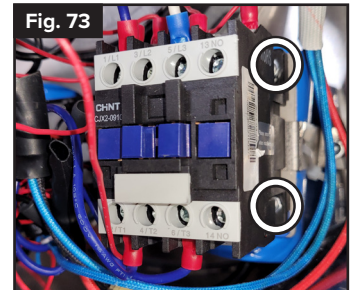
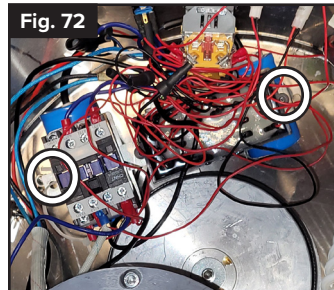

Wiring Diagram

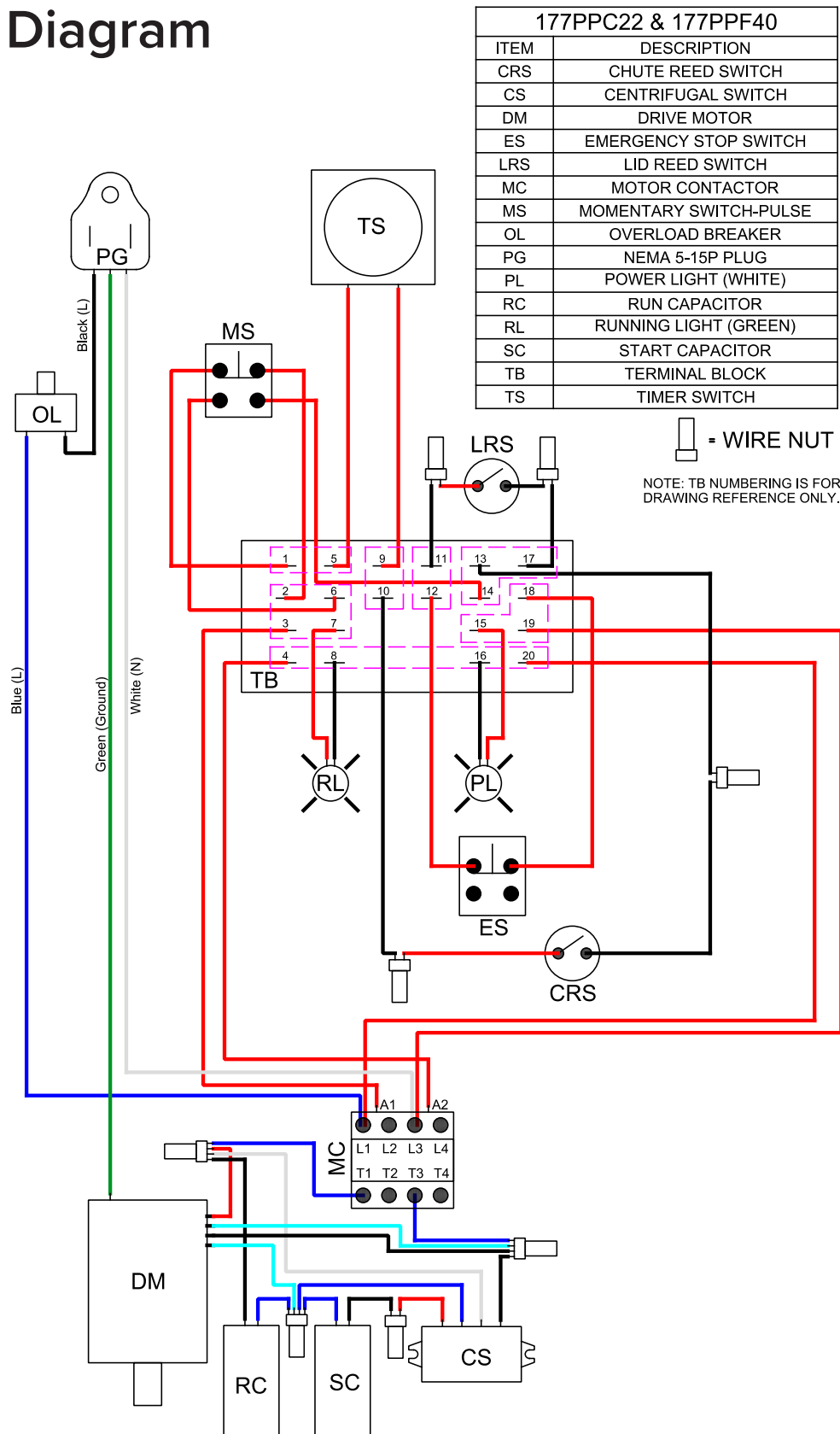

Parts Diagram

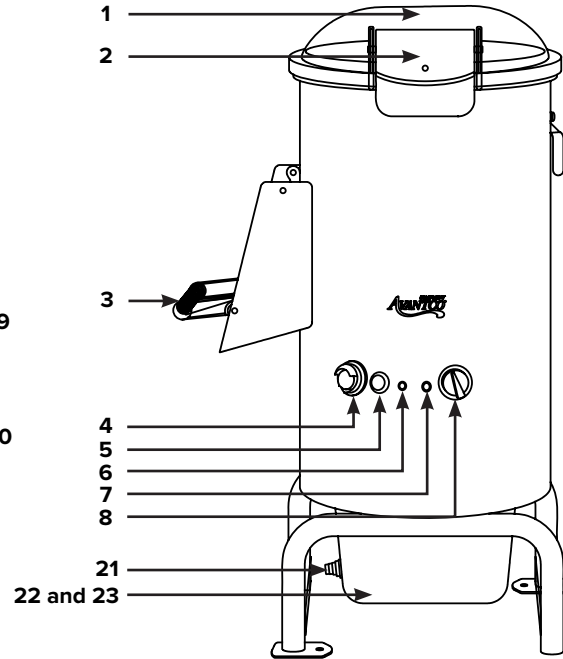
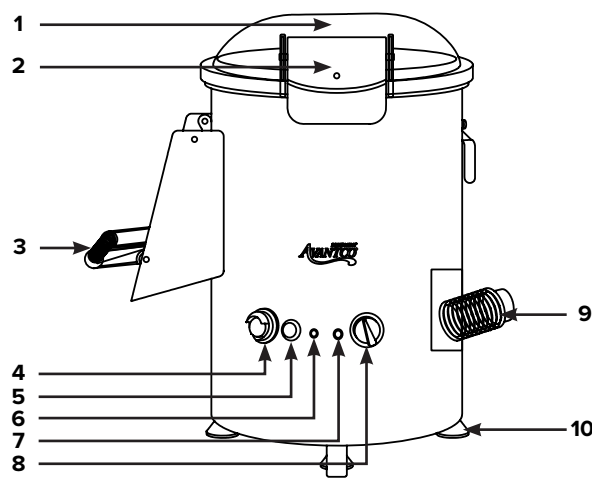

BOTTOM VIEW

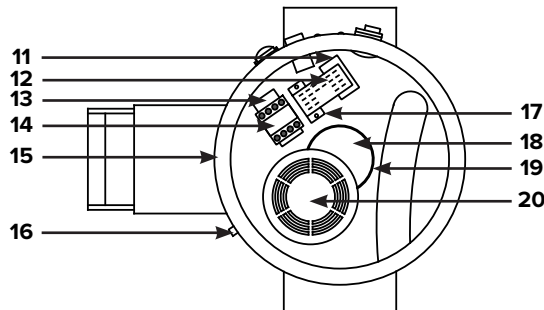

#	Description	Item #
1	Lid	177PPLID
2	Lid Handle / Latch	177PPHANDLE
3	Side Door Assembly	177PPDOOR
4	Emergency Stop Switch	177PPSTOP
5	Pulse Switch	177PPPULSE
6	Power Light (White)	
7	Running Light (Green)	
8	Timer Switch	177PPTIMER
9	Waste Pipe-PPC22 Waste Pipe-PPF40	177PPWASTEP 177PP40WASTE
10	Foot-PPC22	177PPCFOOT
11	Start Capacitor	177PPSCAP
12	Terminal Block	177PPBOARD
13	Run Capacitor-PPC22 Run Capacitor-PPF40	177PP22RCAP 177PP40RCAP

#	Description	Item #
14	Motor Contactor	
15	Switch (Lid and Side Door)	177PPMSWITCH
16	Overload Breaker-PPC22 Overload Breaker-PPF40	177PP22CIRCBRK 177PP40CIRCBRK
17	Centrifugal Switch	177PPCSWITCH
18	Driveshaft Assembly	177PPPULASB
19	Belt	177PPBELT
20	Motor-PPC22 Motor-PPF40	177PP22MOTOR 177PP40MOTOR
21	Pan Joint-PPF40	177PPFJPAN
22	Solid Outer Pan-PPF40	177PPFSPAN
23	Perforated Inner Pan-PPF40	177PPFPPAN
	Rotor Plate (Not Shown)	177PPPLATE
	Block Guide (Not Shown)	177PPGBLOCK